

# Pro-Ag Fixed Bag Lifter

Fixed Bag Lifter-This attachment enables a quick and easy way of handling various bags more efficiently and safer. The fixed arms are available with widths from 900mm to 1030mm therefore offering more versatility.

- Smooth arm design to prevent damage to bags
- Rear support bar stabilises bags during transport
- Handles both 600kg and 1200kg bags
- Arms can be set from standard build 1030mm centres from 900mm to 1030mm centres as a special request option
- All models are complete with brackets

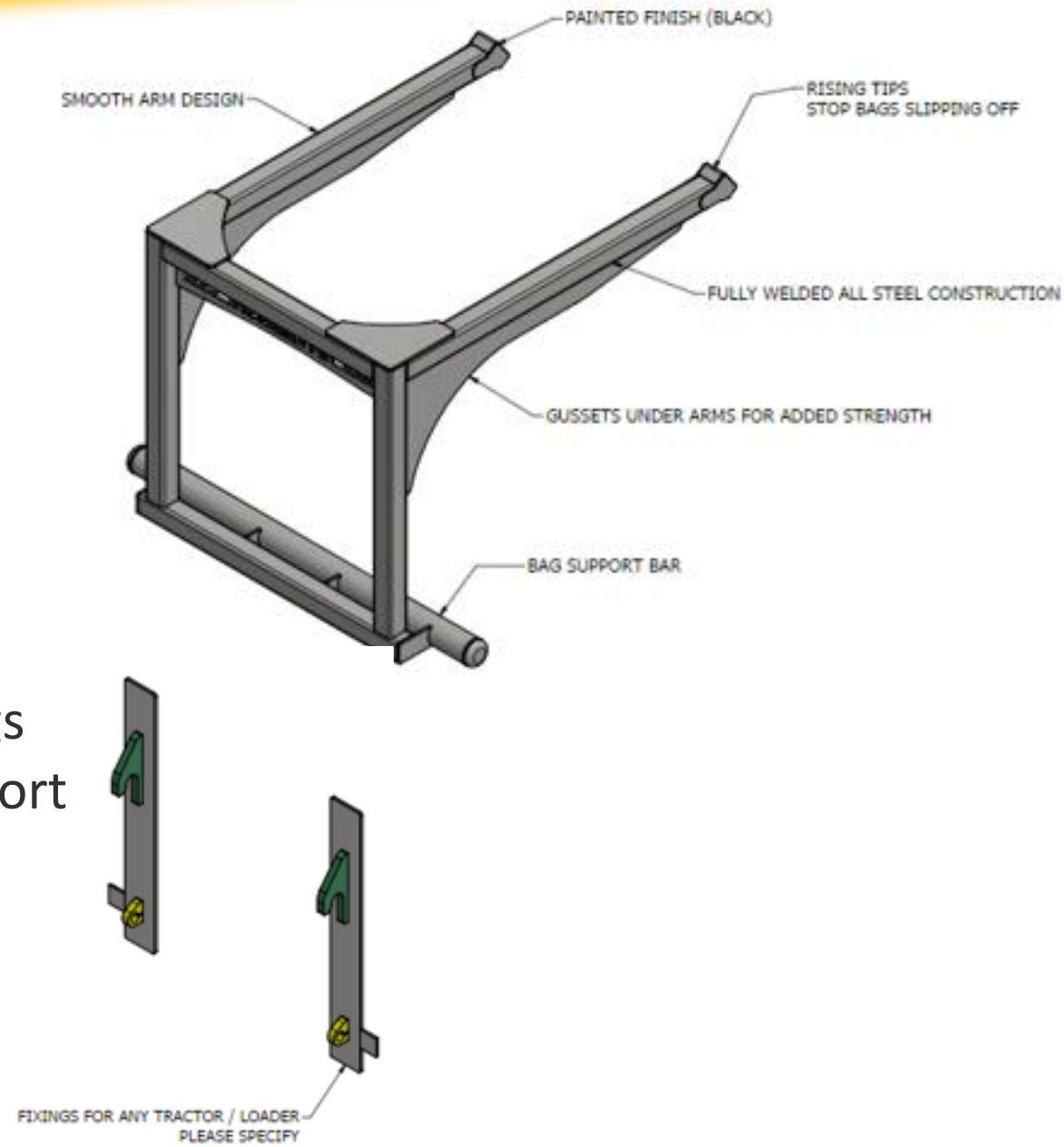

Model	Capacity	Height (mm)	Depth (mm)	Width (mm)	Weight (kg) (without Fixings)
FBL-01	2 x 1200kg/4 x 600kg	1140	1565	1560	200

