

The Strimech Grain Pusher is designed for use with telehandlers, loaders and Loading Shovels with a number of machine quick hitch pick up's offered to suit all. The heavy duty design incorporates round and smooth surfaces to prevent grain trapping. A modular design, rubber wear edge giving perfect floor protection, this is a simple bolt-on design allowing it to easily be replaced.

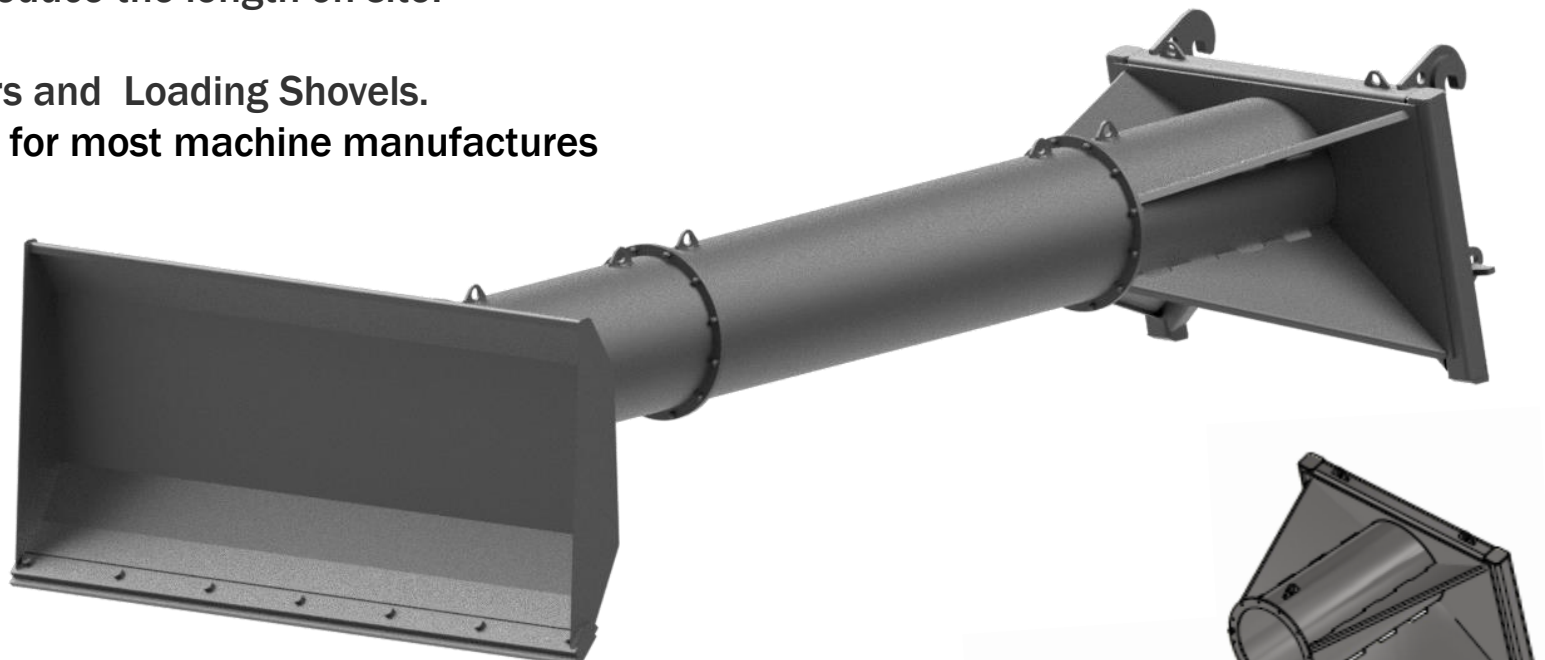

- Modular design enabling simple to extend or reduce the length on site.
- Heavy duty design
- Ideal for Telescopic Handlers, Backhoe Loaders and Loading Shovels.
- Quick Hitch Direct mounted versions available for most machine manufactures
- No grain trap points on frame
- Rubber wear edge for floor protection.
- Tube extensions in 1 and 2 meter lengths.



Model	Length (mm/ft) (without machine Brackets)	Width (mm/ft)	Weight (kg) (without machine Brackets)
MGP76-2	1950/6.4"	2350 / 7'7"	532
MGP76-3	2950/9.7"	2350 / 7'7"	605
MGP76-4	3950/13.0"	2350 / 7'7"	665
MGP76-5	4950/ 16.2"	2350 / 7'7"	738
MGP76-6	5950/19.6"	2350 / 7'7"	798
MGP76-7	6950/22.9"	2350 / 7'7"	880

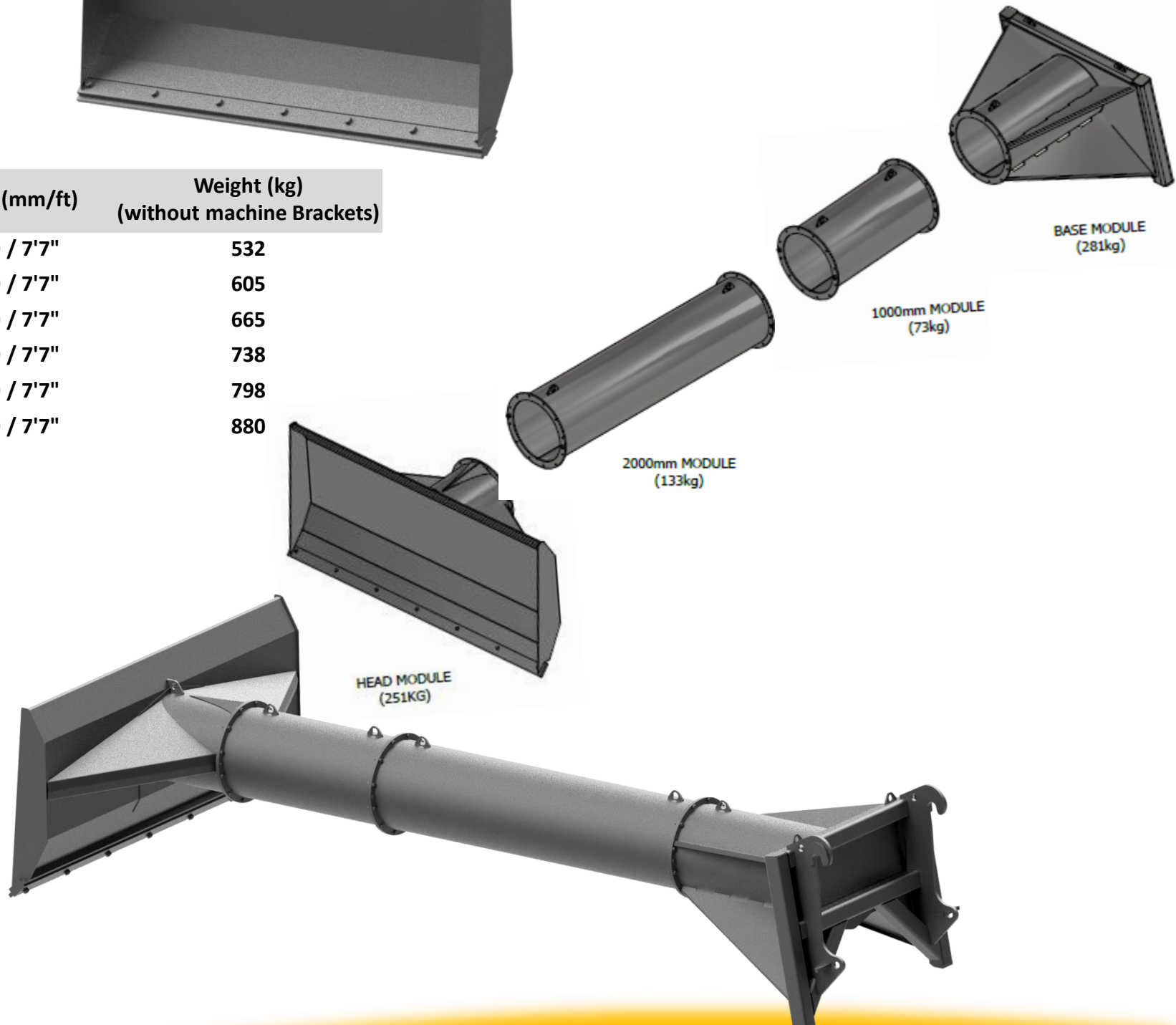

Longmore Avenue,  
Walsall,  
WS2 0BW.  
01922 649700  
[www.strimech.co.uk](http://www.strimech.co.uk)

